

SPLIT TYPE
ROOM AIR CONDITIONER
WALL MOUNTED TYPE

SERVICE MANUAL

Indoor unit Outdoor unit
ASYA18LEC AOYR18LEC



CONTENTS

SPECIFICATIONS	1
DIMENSIONS	2
REFRIGERANT SYSTEM DIAGRAM	3
CIRCUIT DIAGRAM	4
INDOOR PCB CIRCUIT DIAGRAM	5
OUTDOOR PCB CIRCUIT DIAGRAM	8
ERROR CONTENTS	10
PARTS (indoor unit)	12
PARTS (outdoor unit)	16
ACCESSORIES	19

SPECIFICATIONS

ELECTRICAL DATA

INDOOR UNIT	ASYA18LEC
OUTDOOR UNIT	AOYR18LEC
POWER SOURCE	230 V
FREQUENCY	50 Hz
COOLING CAPACITY	5.20 kW
HEATING CAPACITY	6.30 kW
RUNNING CURRENT (Cool)	6.8 A
RUNNING CURRENT (Heat)	7.6 A
INPUT WATTS (Cooling)	1.52 kW
INPUT WATTS (Heating)	1.71 kW
E.E.R. (Cooling)	3.42 kW/kW
C.O.P. (Heating)	3.68 kW/kW
MAXIMUM CURRENT (Cool)	9.0 A
MAXIMUM CURRENT (Heat)	12.5 A
MOISTURE REMOVAL	2.8 L/hr
AIR CIRCULATION HIGH	900 m ³ /hr

FAN MOTOR

POWER SOURCE		230 V
INDOOR UNIT	High speed	1,220 r.p.m.
	Middle	1,020 r.p.m.
	Low	900 r.p.m.
	Quiet	710 r.p.m.
OUTDOOR UNIT		1,050 r.p.m.

NOISE LEVEL

INDOOR UNIT (Cooling / Heating)	High	43 dB / 42 dB
	Middle	37 dB / 37 dB
	Low	33 dB / 33 dB
	Quiet	26 dB / 25 dB
OUTDOOR UNIT (Cool / Heat)		50 dB / 52 dB

COMPRESSOR AND REFRIGERANT

TYPE	Hermetic type, 4 pole, Scroll, DC inverter motor	
DISCRIMINATION	808 903 80	
WEIGHT (with oil)	9.0 kg	
REFRIGERANT TYPE	R410A	
PRECHARGED REFRIGERANT	1,200 g	
FULL CHARGE	Pipe Length 15 m	1,200 g
	20 m	1,300 g
	25 m	1,400 g
ADDITIONAL CHARGE	20 g/m	
MAX HEIGHT	20 m	

DIMENSIONS

INDOOR UNIT	H x W x D	320 x 998 x 228 mm
OUTDOOR UNIT	H x W x D	620 x 790 x 298 mm

WEIGHT

INDOOR UNIT	Gross / Net	18 kg / 14 kg
OUTDOOR UNIT	Gross / Net	45 kg / 40 kg

OUTLINE AND DIMENSIONS

Unit : mm

INDOOR UNIT

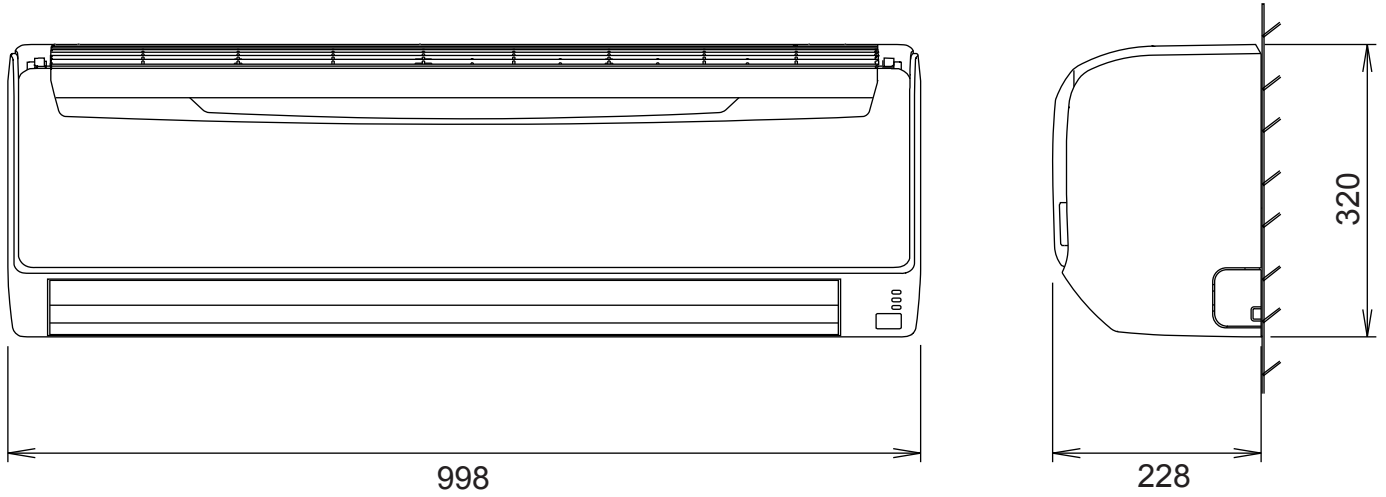

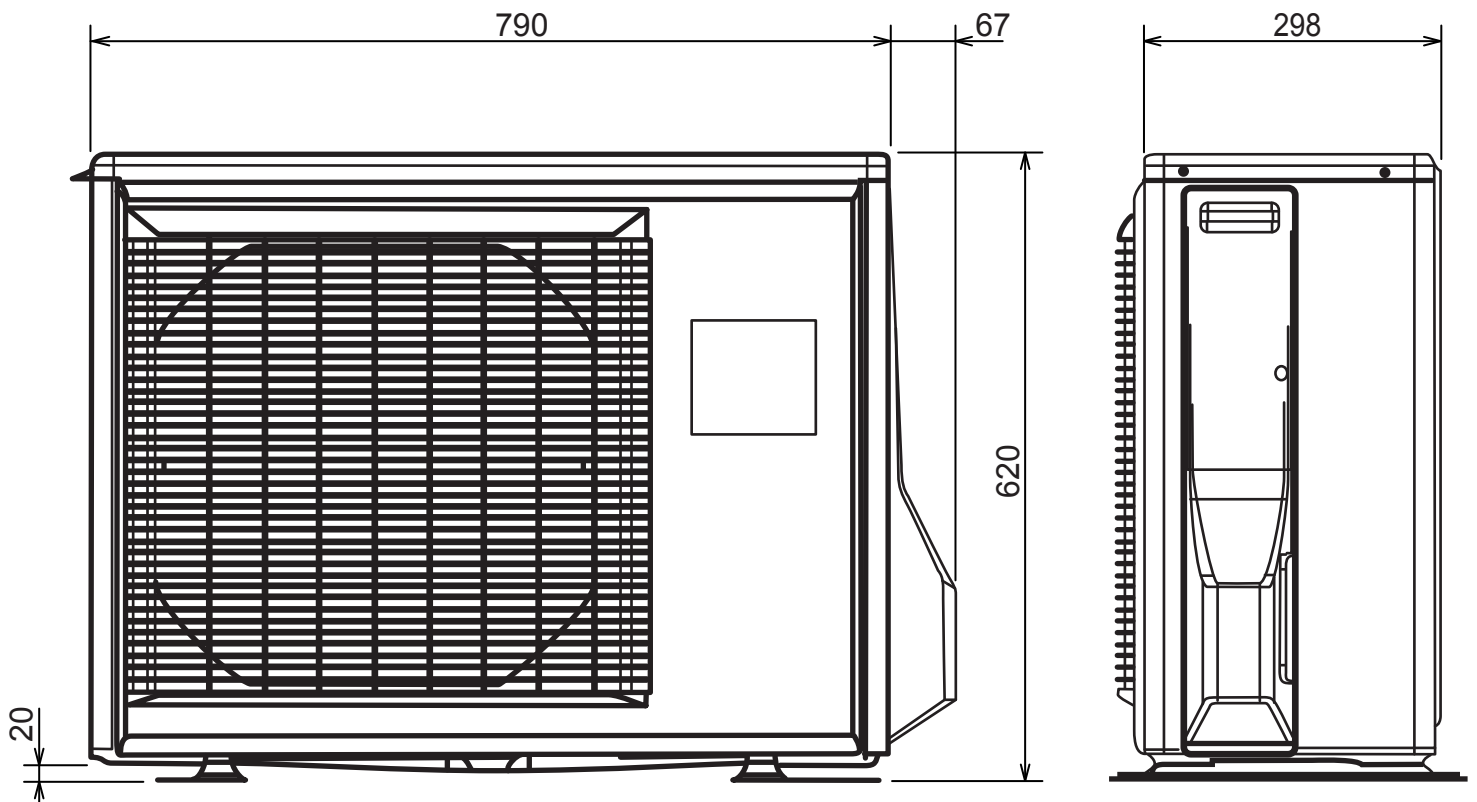

OUTDOOR UNIT

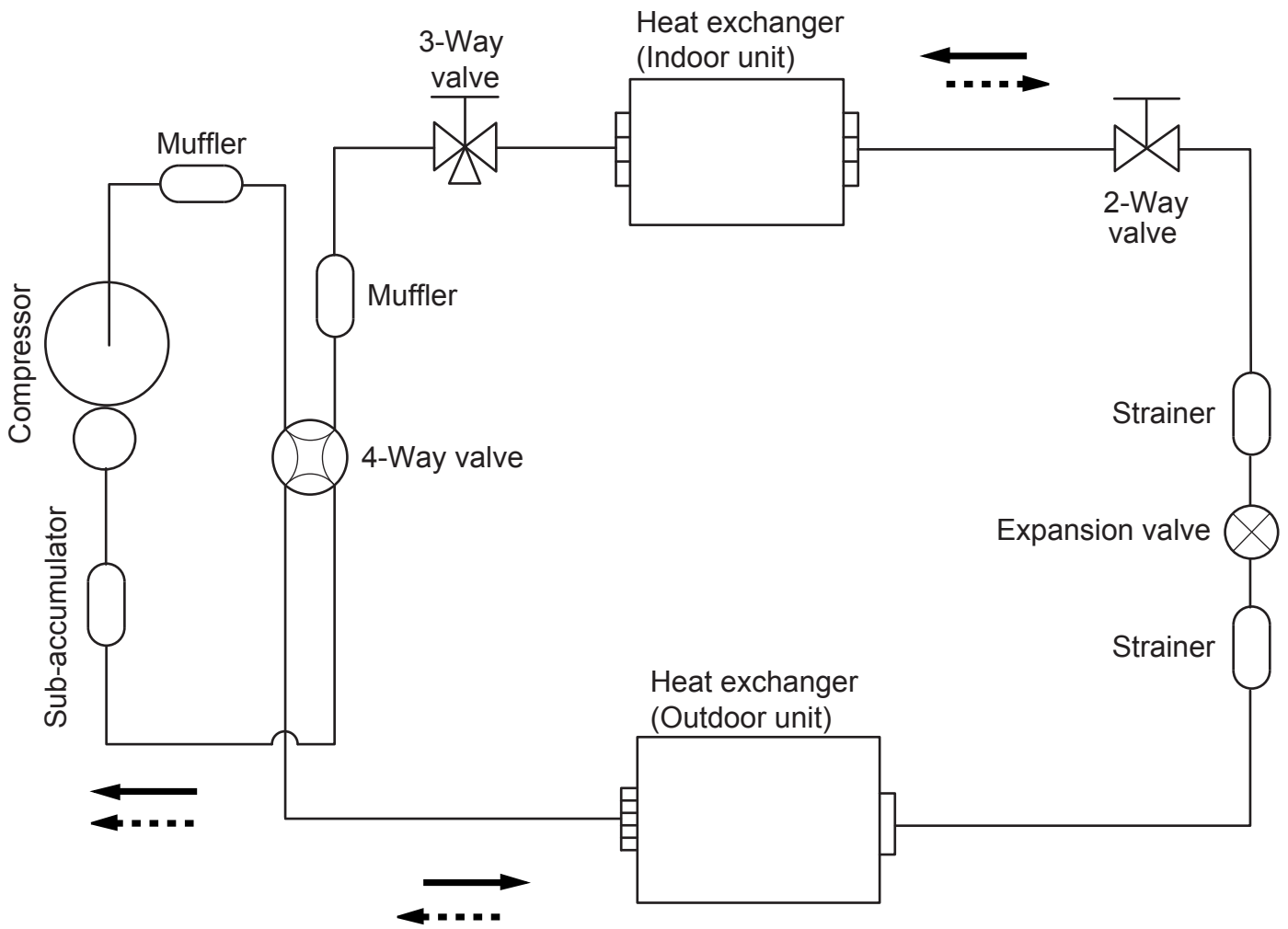

REFRIGERANT SYSTEM DIAGRAM



Refrigerant direction

-  Cooling
-  Heating

Refrigerant pipe diameter

- Liquid : 1/4" (6.35 mm)
- Gas : 1/2" (12.7 mm)

CIRCUIT DIAGRAM

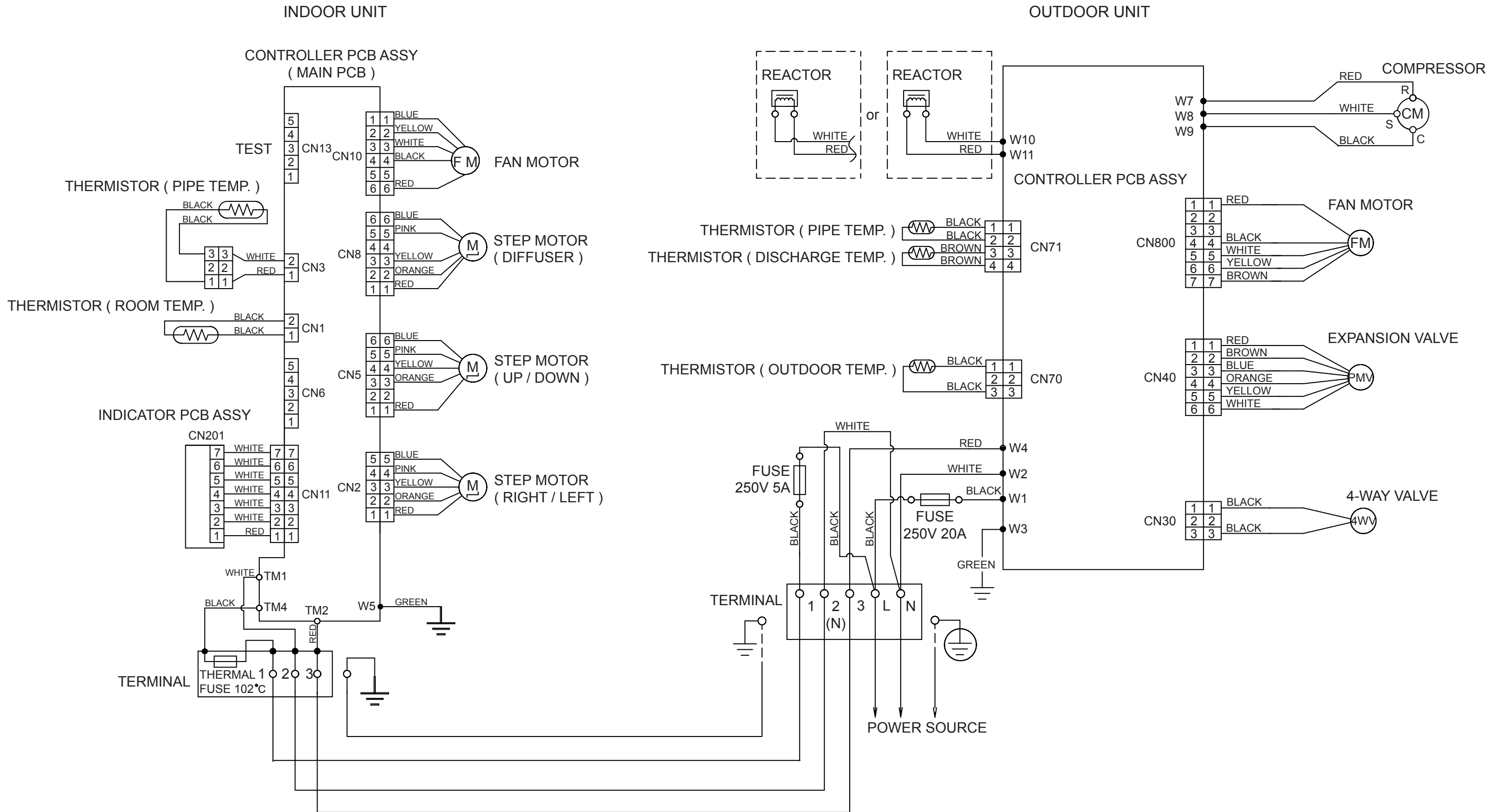

PCB Circuit Diagrams

not available at time of publication

ERROR CONTENTS

Error	Display		Error
	Operation LED	Timer LED	
Serial signal error	Off	2 flash	Serial signal (reverse) error, at operation start up
		3 flash	Serial signal (reverse) error, during operation
		4 flash	Serial signal (forward) error, at operation start up
		5 flash	Serial signal (forward) error, during operation
		8 flash	Wired remote controller error
Indoor unit thermistor error	2 flash	2 flash	Indoor temperature thermistor open / short
		3 flash	Heat exchanger middle thermistor open / short
Outdoor unit thermistor error	3 flash	2 flash	Discharge thermistor open / short
		3 flash	Heat exchanger thermistor open
		4 flash	Outdoor temperature thermistor open / short
		8 flash	Compressor temperature thermistor open / short
Indoor unit control error	4 flash	2 flash	Forced automatic SW welded
		3 flash	Main relay welded
		4 flash	Power interruption error
		7 flash	VDD permanent stop protection
		8 flash	reverse VDD permanent stop protection
Outdoor unit control error	5 flash	2 flash	Current trip error
		3 flash	CT abnormal
		5 flash	Compressor location detection error
		6 flash	Outdoor unit fan drive system abnormal
Indoor fan motor error	6 flash	2 flash	Abnormal lock
		3 flash	Abnormal rotation
Refrigerant cycle error	7 flash	2 flash	Discharge Temperature abnormal
		3 flash	Cooling high pressure abnormal rise
		5 flash	Pressure switch trouble
Optional function error	8 flash	2 flash	Active filter voltage trouble (second time)
		3 flash	Active filter voltage trouble (first time)
		4 flash	PFC circuit error
Model information error	0.1 sec on/off	0.1 sec on/off	Model information error

OUTDOOR UNIT

LED	ERROR
0.5 second on / 0.5 second off	Overload protection
on	Discharge temperature abnormal
0.1 second on / 0.1 second off	Thermistor abnormal
2.0 second on / 2.0 second off	CT abnormal
0.1 second on / 2.0 second off	Compressor location abnormal
5.0 second on / 5.0 second off	Fan abnormal

PARTS

INDOOR UNIT

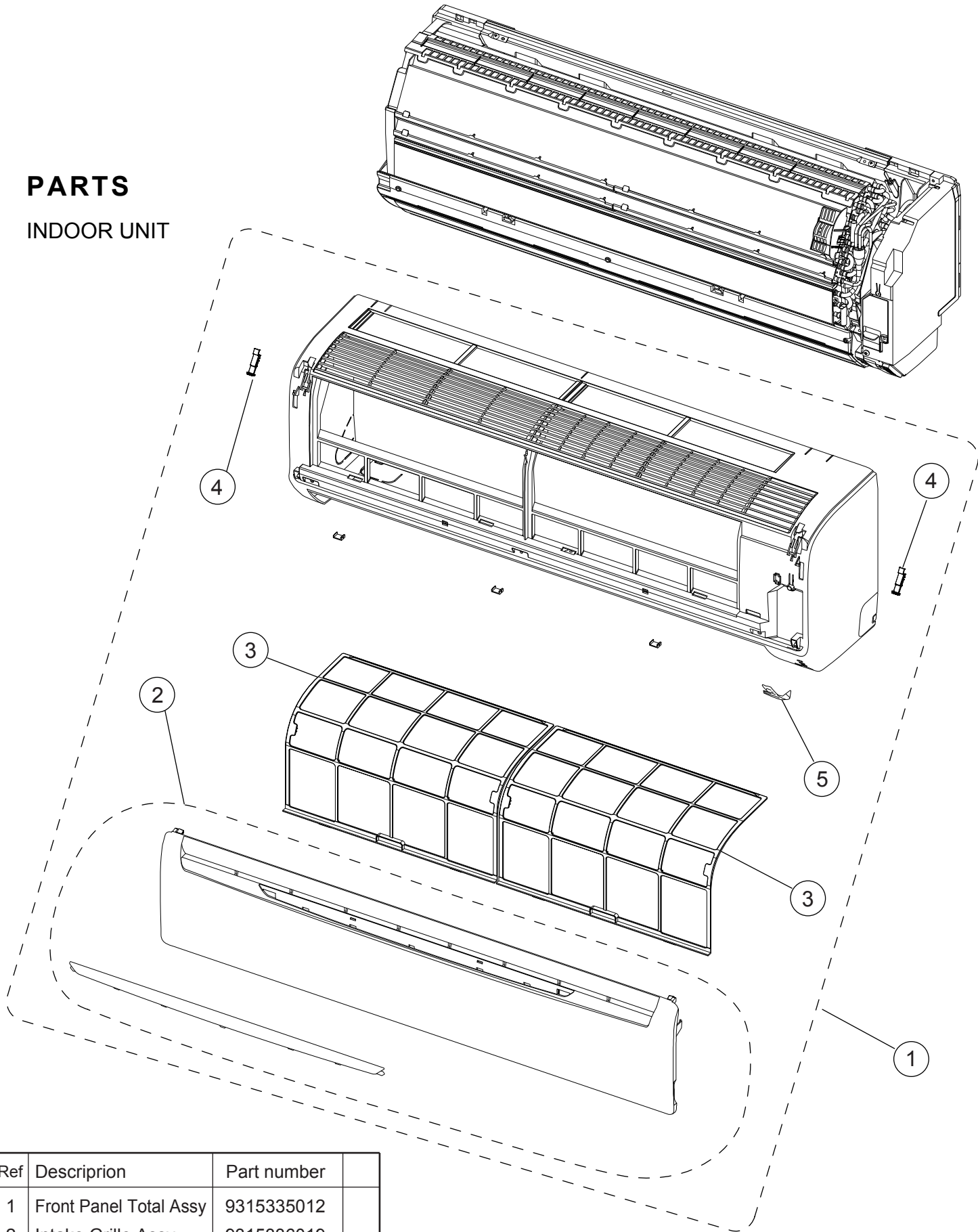

Ref	Description	Part number
1	Front Panel Total Assy	9315335012
2	Intake Grille Assy	9315336019
3	Air Filter	9315014016
4	Clamper Grille	9306755010
5	Receiver Window	9315010018
--	Air Clean Filter Assy	9315212016
--	Remote Control	9317445009
--	Remote Control Holder	9305642045

INDOOR UNIT

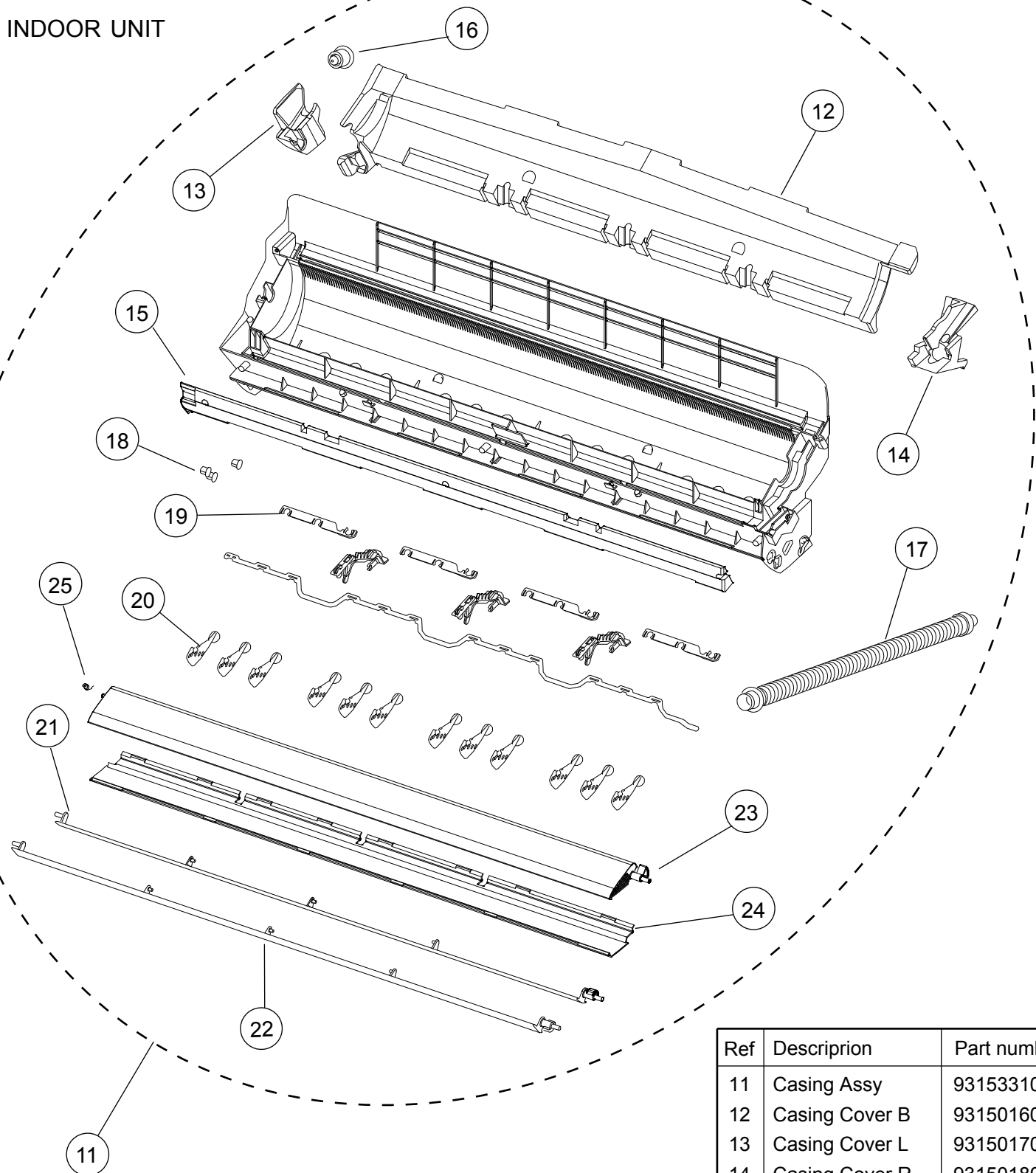

Ref	Description	Part number
11	Casing Assy	9315331038
12	Casing Cover B	9315016010
13	Casing Cover L	9315017017
14	Casing Cover R	9315018014
15	Casing Cover F	9315019011
16	Drain Cap	9367677009
17	Drain Hose Assy	9315769015
18	Bush B	9312156016
19	Spacer B	9312441013
20	R and L Louver	9311997016
21	Louver U	9315000019
22	Louver Z	9315001016
23	Diffuser U	9315002013
24	Diffuser Z	9315003010
25	Spring C	9314142017
--	Fan Guard	9305751051
--	Fan Guard Holder R	9315814012
--	Fan Guard Holder L	9315815019

INDOOR UNIT

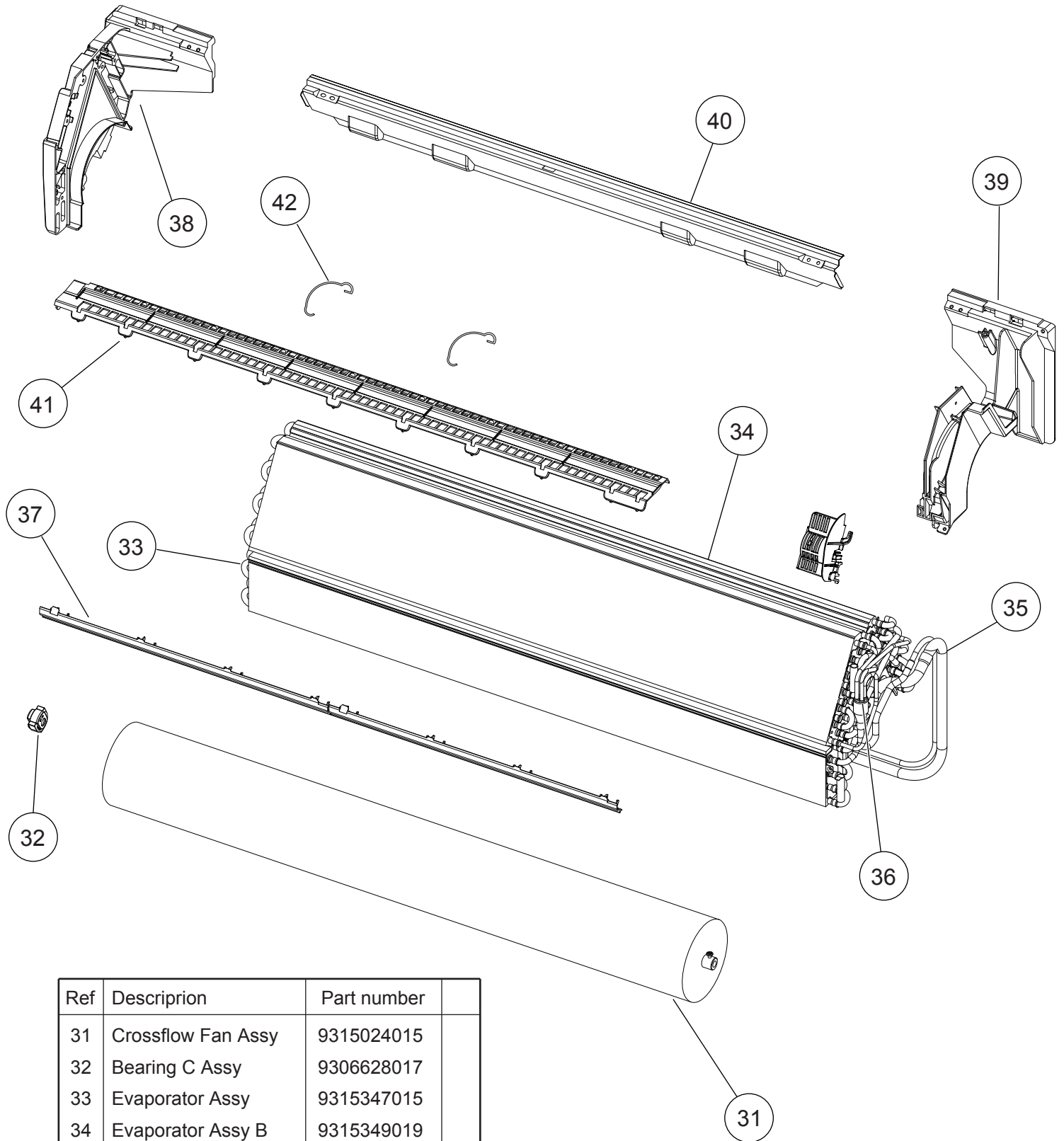

Ref	Description	Part number
31	Crossflow Fan Assy	9315024015
32	Bearing C Assy	9306628017
33	Evaporator Assy	9315347015
34	Evaporator Assy B	9315349019
35	Connection Pipe Assy	9315354020
36	Distributor Assy	9316989016
37	Water Seal	9315251015
38	Evaporater Holder L	9314995019
39	Evaporater Holder R	9314994012
40	Rear Bracket	9315022011
41	Filter Guide	9315013019
42	Filter Guard	9315411013

INDOOR UNIT

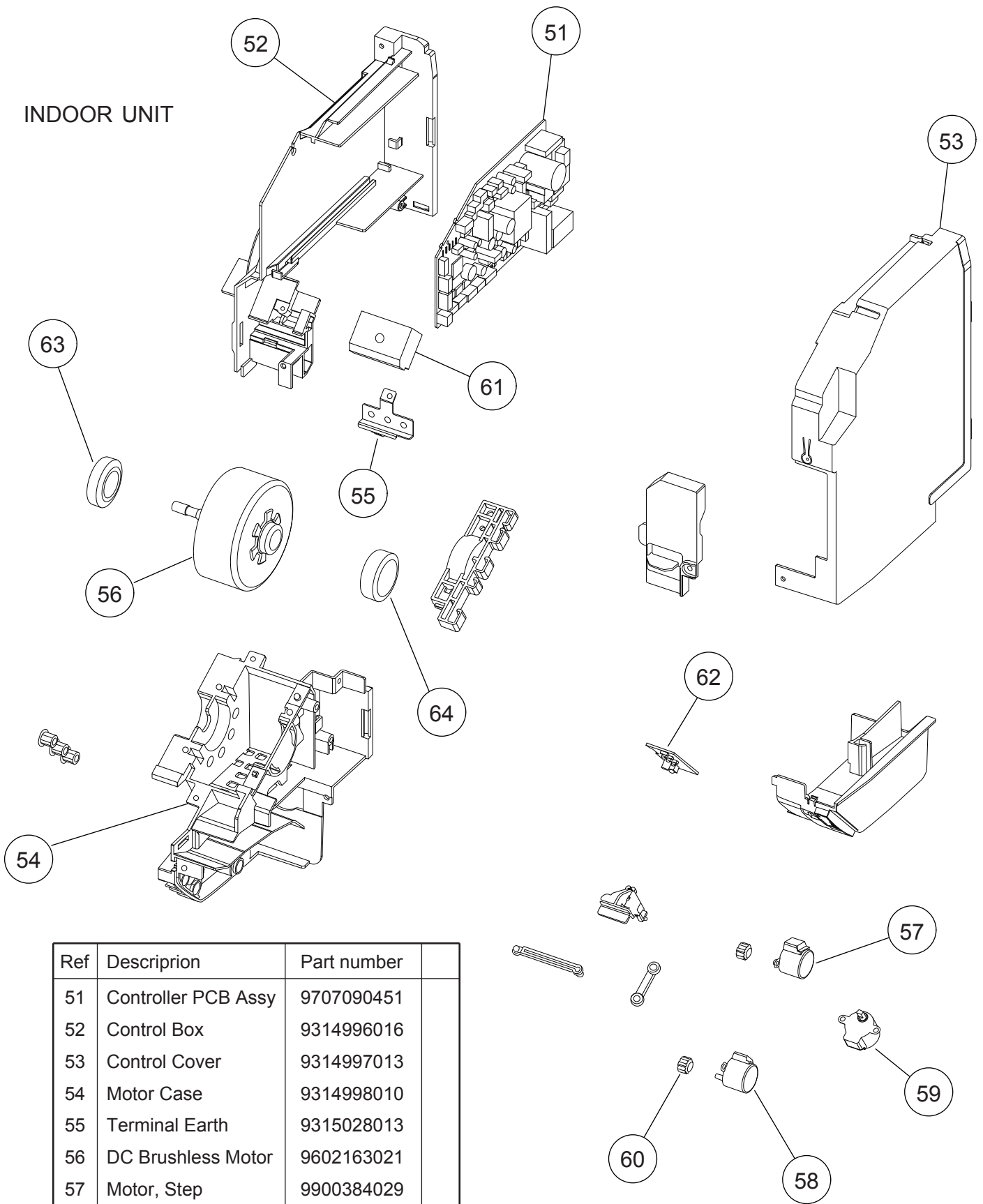

Ref	Description	Part number
51	Controller PCB Assy	9707090451
52	Control Box	9314996016
53	Control Cover	9314997013
54	Motor Case	9314998010
55	Terminal Earth	9315028013
56	DC Brushless Motor	9602163021
57	Motor, Step	9900384029
58	Motor, Step	9900384036
59	Motor, Step	9900139063
60	Gear A	9309994003
61	Terminal	9900447014
62	Indicator PCB Assy	9707210019
63	Motor Cushion N	9312979011
64	Motor Cushion NR	9313168018
--	Pipe Thermistor	9900389017

Room thermistor is tied to a Controller PCB assy.

PARTS

OUTDOOR UNIT

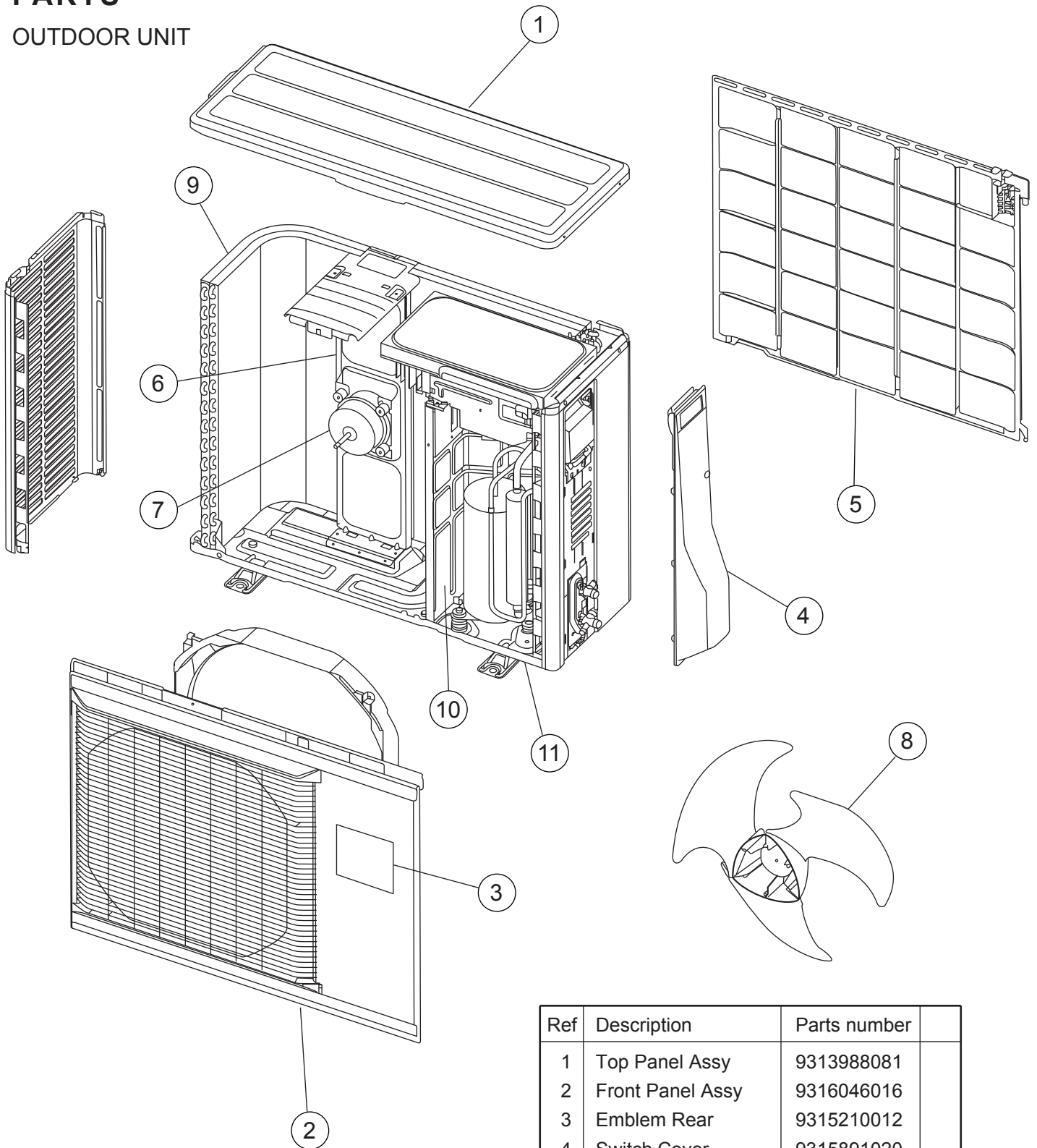

Ref	Description	Parts number
1	Top Panel Assy	9313988081
2	Front Panel Assy	9316046016
3	Emblem Rear	9315210012
4	Switch Cover	9315891020
5	Protective Net	9331640008
6	Motor Bracket	9315894014
7	DC Brushless Motor	9602724017
8	Propeller Fan	9313808013
9	Condenser Assy	9317119009
10	Separate Wall Assy	9331722001
11	Base Assy	9316885004
--	Drain Pipe	9303029022

OUTDOOR UNIT

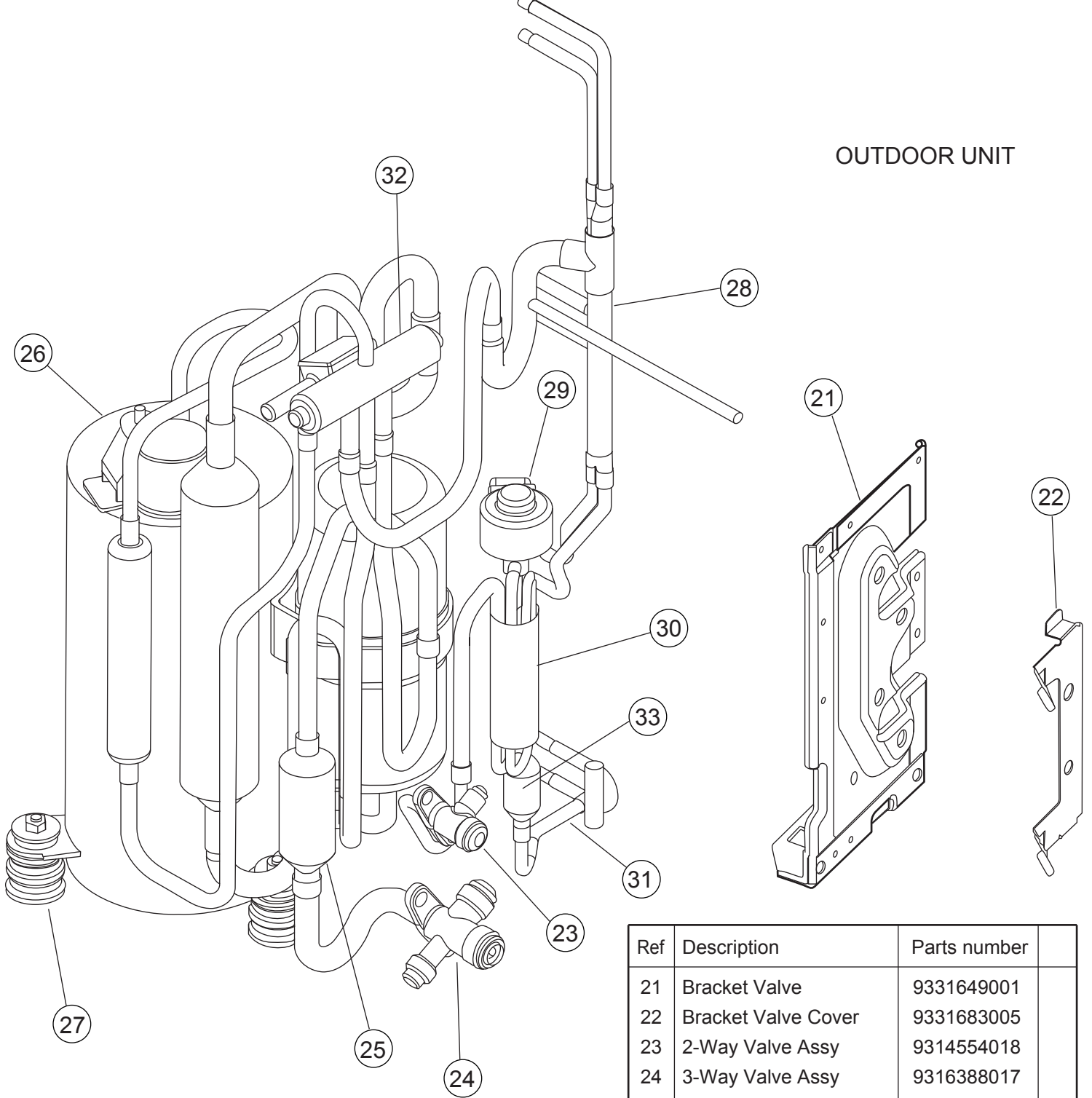





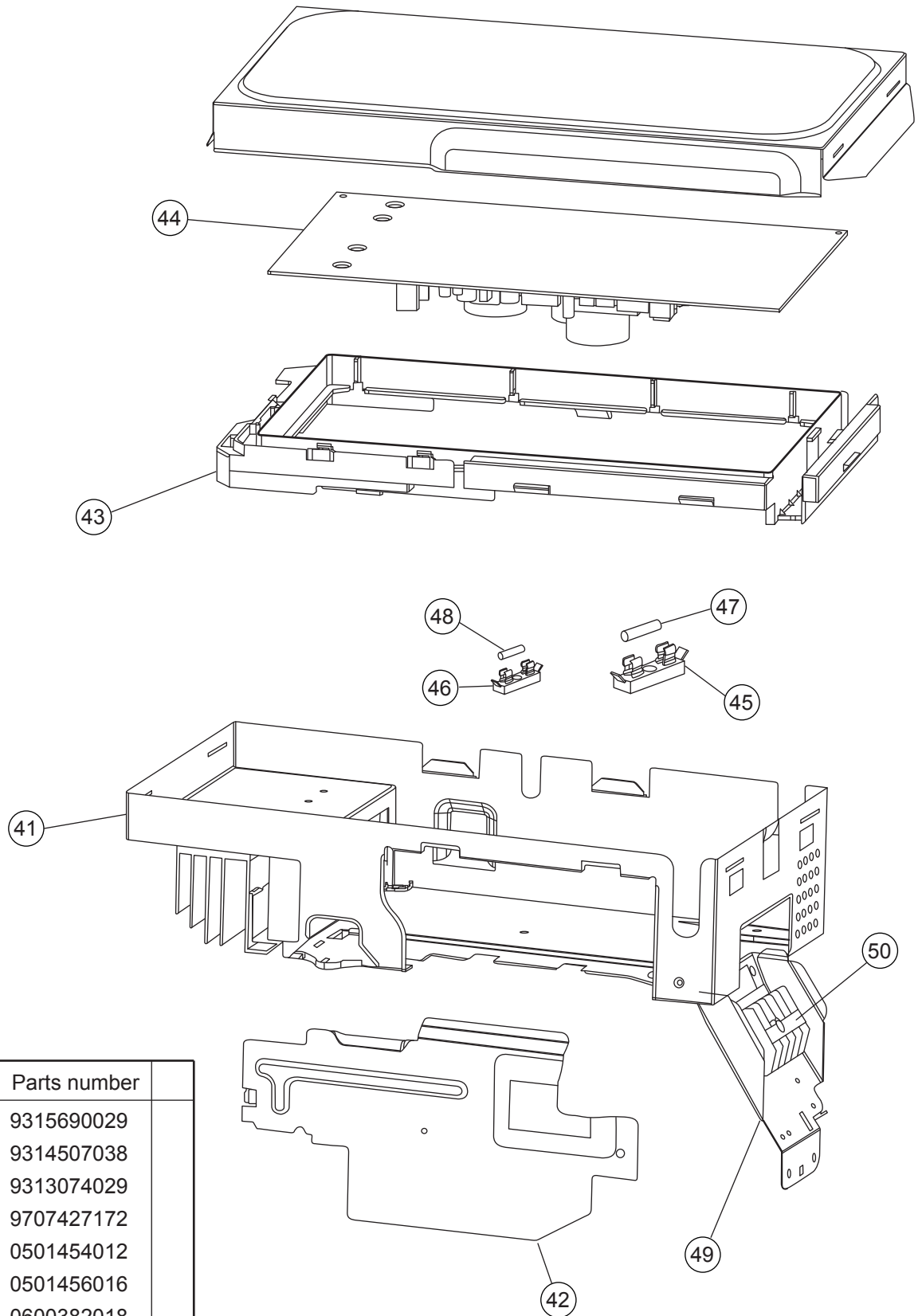

Ref	Description	Parts number
21	Bracket Valve	9331649001
22	Bracket Valve Cover	9331683005
23	2-Way Valve Assy	9314554018
24	3-Way Valve Assy	9316388017
25	Muffler	9316276017
26	Compressor Assy	9313279011
27	Rubber Cushion	9306410001
28	Entrance Pipe Assy	9317121019
29	Expansion Valve Coil	9900057039
30	Pulse Motor Valve Assy	9314557019
31	Pipe (Cond Exit) Assy	9317105002
32	4-Way Valve	9900162016
33	Strainer C	9311440017
--	Solenoid	9970055010
--	Pipe (Cond Sepa) Assy	9317127004
--	Discharge Pipe Assy	9331772006
--	Joint Pipe (Cond)	9331780018
--	Suction Pipe Assy	9331775007
--	Joint Pipe (3WV) Assy	9331777001
--	Reactor Assy	9900354022

OUTDOOR UNIT

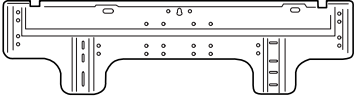

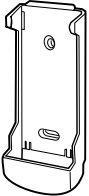
Ref	Description	Parts number
41	Inverter Case Assy	9315690029
42	Inverter Case Cover	9314507038
43	PCB Holder	9313074029
44	PCB Assy	9707427172
45	Fuse Holder	0501454012
46	Fuse Holder	0501456016
47	Fuse	0600382018
48	Fuse	0600376086
49	Bracket Terminal	9315233035
50	Terminal	9703874031
--	Terminal Cover	9331704007
--	Thermistor Assy	9900148041
--	Outdoor Thermistor	9900210038

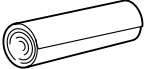
ACCESSORIES

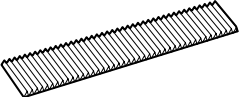
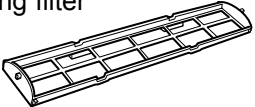
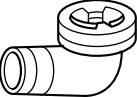
Name and Shape	Part number
Wall hook bracket 	9315023018
Remote control 	9317445009
Remote control holder 	9305642045
Battery (penlight) 	0600185527
Cloth tape 	9310519004
Tapping screw (big) 	0700076046
Tapping screw (small) 	0700019036
Air cleaning filter 	9312153060
	9311925071
Air cleaning filter frame 	9368568009
Drain pipe 	9303029022

0804G3453